

ebm-papst Mulfingen GmbH & Co. KG  
 Bachmühle 2  
 D-74673 Mulfingen  
 Phone +49 7938 81-0  
 Fax +49 7938 81-110  
 info1@de.ebmpapst.com  
 www.ebmpapst.com

## CONTENTS

<b>1. SAFETY REGULATIONS AND NOTES</b>	<b>1</b>
1.1 Levels of hazard warnings	1
1.2 Staff qualification	1
1.3 Basic safety rules	1
1.4 Electrical voltage	1
1.5 Safety and protective functions	2
1.6 Electromagnetic radiation	2
1.7 Mechanical movement	2
1.8 Deflagration	2
1.9 Emission	2
1.10 Hot surface	2
1.11 Transport	2
1.12 Storage	3
1.13 Disposal	3
<b>2. PROPER USE</b>	<b>3</b>
<b>3. TECHNICAL DATA</b>	<b>5</b>
3.1 Graphic rendition of products	5
3.2 Nominal data	6
3.3 Technical description	6
3.4 Mounting data	6
3.5 Transport and storage conditions	6
3.6 Electromagnetic compatibility	6
<b>4. CONNECTION AND START-UP</b>	<b>7</b>
4.1 Connecting the mechanical system	7
4.2 Connecting the electrical system	7
4.3 Connection via plug	7
4.4 Connection diagram	9
4.5 Checking the connections	10
4.6 Switch on device	10
4.7 Switching off the device	10
<b>5. INTEGRATED PROTECTIVE FUNCTIONS</b>	<b>10</b>
<b>6. MAINTENANCE, MALFUNCTIONS, POSSIBLE CAUSES AND REMEDIES</b>	<b>11</b>
6.1 Cleaning	11
6.2 Safety test	11

## 1. SAFETY REGULATIONS AND NOTES

Please read these operating instructions carefully before starting to work with the device. Observe the following warnings to prevent malfunctions or physical damage to both property and people.

These operating instructions are to be regarded as part of this device. If the device is sold or transferred, the operating instructions must accompany it.

These operating instructions may be duplicated and forwarded for information about potential dangers and their prevention.

### 1.1 Levels of hazard warnings

These operating instructions use the following hazard levels to indicate potentially hazardous situations and important safety regulations:



#### DANGER

Indicates an imminently hazardous situation which, if not avoided, will result in death or serious injury. Compliance with the measures is mandatory.

#### WARNING

Indicates a potentially hazardous situation which, if not avoided, could result in death or serious injury. Exercise extreme caution while working.

#### CAUTION

Indicates a potentially hazardous situation which, if not avoided, may result in minor or moderate injury or damage of property.

#### NOTE

A potentially harmful situation can occur and, if not avoided, can lead to property damage.

### 1.2 Staff qualification

Only specialised electrical personnel may install the device, perform the test run and work on the electrical system.

Only trained and authorised specialist personnel are permitted to transport, unpack, assemble, operate or maintain the device, or to use it in any other manner.

### 1.3 Basic safety rules

Any safety hazards stemming from the device must be re-evaluated once it is installed in the end device.

Observe the following when working on the unit:

- Do not make any modifications, additions or conversions to the device without the approval of ebm-papst.

### 1.4 Electrical voltage

- Check the electrical equipment of the device at regular intervals, refer to chapter 6.2 Safety test.
- Replace loose connections and defective cables immediately.



#### DANGER

##### Electrical load on the device

Risk of electric shock

→ Stand on a rubber mat if you are working on an electrically charged device.

#### WARNING

##### Terminals and connections have voltage even with a unit that is shut off

Electric shock

→ Wait five minutes after disconnecting the voltage at all poles before opening the device.

**CAUTION**

**In the event of failure, there is electric voltage at the rotor and impeller**

The rotor and impeller are base insulated.

→ Do not touch the rotor and impeller once they are installed.

**CAUTION**

**If control voltage is applied or a speed setpoint is stored, the motor automatically restarts, e.g. after a power failure.**

Danger of injury

→ Keep out of the danger zone of the device.

→ When working on the device, switch off the mains supply voltage and secure the latter from being switched on again.

→ Wait until the device stops.

→ After working on the device, remove any used tools or other objects from the device.

**1.5 Safety and protective functions****DANGER**

**Missing safety device and non-functioning safety device**

If there is no safety device, you could be seriously injured, for example by reaching into the running device with your hands.

→ Operate the device only with a fixed and isolating safety protection and a fixed guard grille. The guard must withstand the kinetic energy of a fan blade detaching at maximum speed.

→ The device is a built-in component. You, the owner/operator, are responsible for providing adequate protection for the device.

→ Instantly stop the device once you detect a missing or ineffective protective feature.

**1.6 Electromagnetic radiation**

Interference from electromagnetic radiation is possible, e.g. in conjunction with open and closed-loop control devices.

If unacceptable emission intensities occur when the fan is installed, appropriate shielding measures have to be taken by the user.

**NOTE**

**Electrical or electromagnetic interferences after integrating the device in installations on the customer's side.**

→ Verify that the entire setup is EMC compliant.

**1.7 Mechanical movement****DANGER**

**Danger of injury from open blower**

Gas escapes. When the blower is open, you come into contact with rotating and electrically live parts. Escaping gas may also cause explosions.

→ Never open the blower.

**WARNING**

**Rotating device**

Long hair, loose items of clothing and jewellery could become entangled and pulled into the device. You could be injured.

→ Do not wear any loose clothing or jewellery while working on rotating parts.

→ Protect long hair by wearing a cap.

**WARNING**

**Flying parts**

Missing safety devices may cause fan blades to be ejected at high speeds, causing bodily harm.

→ Take appropriate safety measures.

The safety devices must prevent contact with rotating parts and the printed circuit board.

**1.8 Deflagration****DANGER**

**Gas escapes through leaky housing after deflagration**

Danger of injury

→ After a deflagration, check that the housing of the gas blower is tightly sealed.

→ Replace any gas blower with a leaky housing.

**DANGER**

**Fire and deflagration hazard**

The gas blower is not approved according to Ex protection guidelines. Rotating parts can scrape against stationary parts. This may cause sparks and chips. The surface temperature may rise, resulting in a fire.

→ Check which hazards arise from installing, operating, servicing or disposing the gas blower in conjunction with your device.

Prevent these hazards.

Carry out all appropriate measures to this purpose.

**1.9 Emission****WARNING**

**Depending on the installation and operating conditions, a sound pressure level greater than 70 dB(A) may arise.**

Danger of noise-induced hearing loss

→ Take appropriate technical safety measures.

→ Protect operating personnel with appropriate safety equipment, e.g. hearing protection.

→ Also observe the requirements of local agencies.

**1.10 Hot surface****CAUTION**

**High temperature at the electronics enclosure**

Danger of burn injuries

→ Ensure that sufficient protection against accidental contact is provided.

**1.11 Transport****NOTE**

**Transport of blower**

→ Transport the blower in its original packaging only.

→ Secure the blower so that it does not slip, e.g. by using a clamping strap.

### 1.12 Storage

- ; Store the device, partially or fully assembled, in a dry and weatherproof manner in the original packing in a clean environment.
- ; Protect the device from environmental impacts and dirt until the final installation.
- ; We recommend storing the device for a maximum up to one year to guarantee proper operation and longest possible service life.
- ; Even devices explicitly suited for outdoor use are to be stored as described prior to being commissioned.
- ; Maintain the storage temperature, see chapter 3.5 Transport and storage conditions.

### 1.13 Disposal

When disposing of the device, please comply with all relevant requirements and regulations applicable in your country.

## 2. PROPER USE

The device is exclusively designed as a built-in device for moving air and gases according to its technical data.

Any other or secondary use is deemed improper and constitutes a misuse of the device.

Installations on the customer's side must meet the mechanical, thermal and service life-related stresses that can occur.

#### Proper use also includes:

- Moving a gas/air mixture in gas burners with H gas, L gas and liquid gas according to gas family 2 and 3 in accordance with the German DVGW (German Technical and Scientific Association for Gas and Water), worksheet 260, in a concentration of approx. 90 % air and 10 % gas, integrated into an overall system which is designed specifically for operation with this gas type.
- Moving air with a density ranging from 0.9 to 1.2 kg/m<sup>3</sup>.
- Minding the operating instructions.
- Using the device in accordance with the permitted ambient temperature, see chapter 3.5 Transport and storage conditions and chapter .
- Only using the device in stationary systems.
- Installing the device into an overall system for moving air/gas mixtures.
- Commissioning the built-in component only after installation in the customer unit.
- Operating the device with all protective features in place.

#### Improper use

Using the device in the following ways is particularly prohibited and may cause hazards:

- Operating the device with an imbalance, e.g. caused by dirt deposits or icing.
- Moving a medium that contains abrasive particles.
- Moving a highly corrosive medium.
- Moving a medium that contains dust pollution, e.g. suctioning off saw dust.
- Operating the gas blower in an environment that contains flammable gases or dust or combustible solids or fluids.
- Moving an air/gas mixture outside an overall system that fulfils the requirements described above.
- Using the blower as a safety component or for taking on safety-related functions.
- Operation in medical equipment with a life-sustaining or lifesaving function.
- Contact with materials that could damage blower parts, e.g. liquids during cleaning.
- Operation with completely or partially disassembled or modified protective features.
- Exposure to radiation which could damage blower parts, e.g. strong UV radiation.
- Operation with external vibrations.
- Operating the device in an explosive atmosphere.
- Operation with completely or partially disassembled or modified protective features.

- In addition, all application options that are not listed under proper use.



## 3. TECHNICAL DATA

### 3.1 Graphic rendition of products

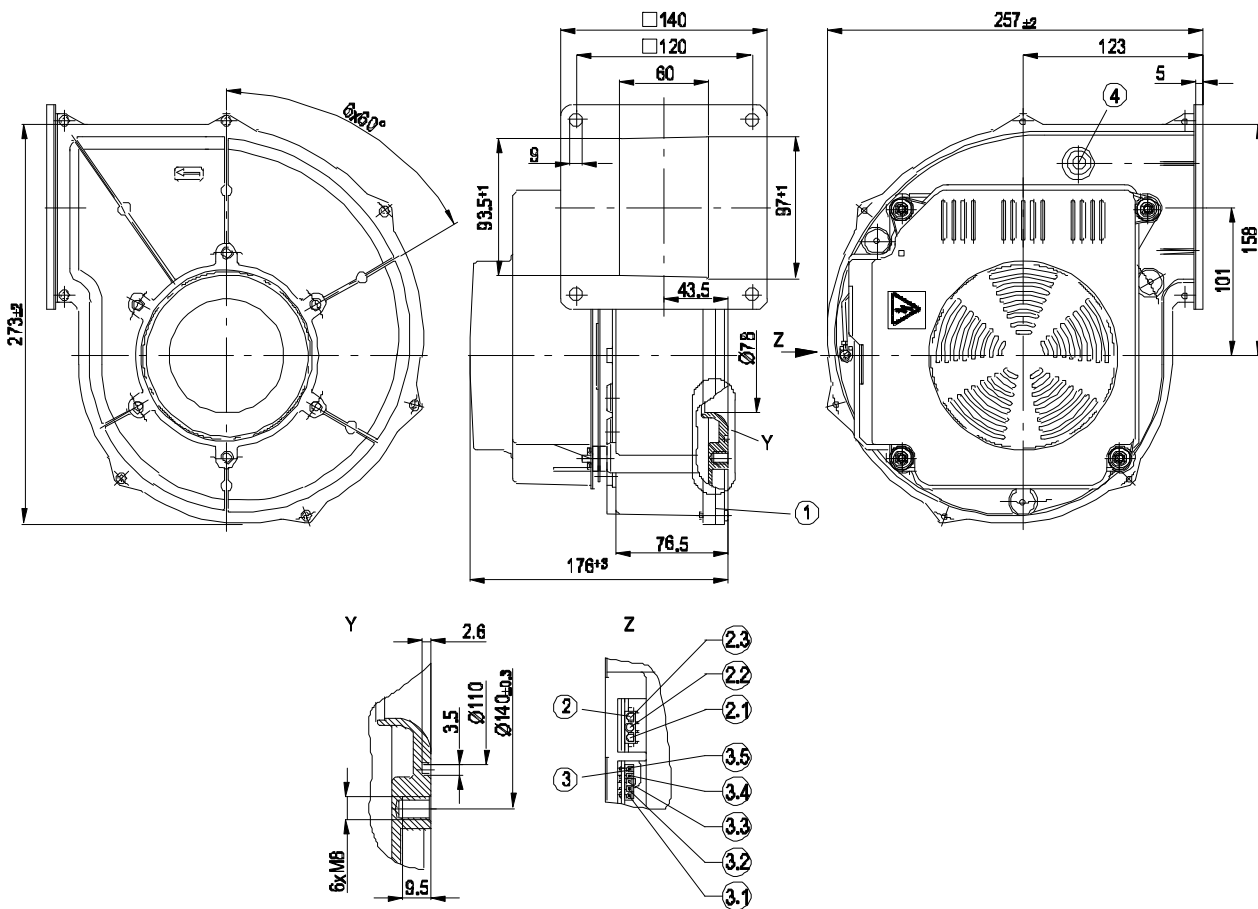

All measures have the unit mm.

<b>I</b>	Housing side parts sealed with NBR round cord (pentane-resistant)
<b>Z</b>	View Z
<b>2</b>	3-pole strip; mating connector (not included in delivery): tyco No. 350 766-1; female connector: No. 926 884-1
<b>2.1</b>	L
<b>2.2</b>	N
<b>2.3</b>	PE
<b>3</b>	5-pole strip; mating connector (not included in delivery) Molex No. 39-01-4050, female connector Molex No. 39-00-0059
<b>3.1</b>	(+)
<b>3.2</b>	Speed monitoring
<b>3.3</b>	Not assigned
<b>3.4</b>	PWM input
<b>3.5</b>	(-)
<b>4</b>	Bleeder connection for pressure relief possible



You can control the blower either via the 0-10 VDC input or the PWM input. Note: Inputs cannot be used simultaneously.

### 3.2 Nominal data

<b>Motor</b>	M1G074-CF
<b>Phase</b>	1~
<b>Nominal voltage in VAC</b>	115
<b>Frequency in Hz</b>	50/60
<b>Type of data definition</b>	fa
<b>Speed in min-1</b>	5730
<b>Power input in W</b>	345
<b>Current draw in A</b>	4.0
<b>Min. ambient temperature in °C</b>	- 25
<b>Max. ambient temperature in °C</b>	+ 55
<b>Min. temp. of flow medium in °C</b>	-25
<b>Max. temp. of flow medium in °C</b>	+80

ml = max. load · me = max. efficiency · fa = running at free air

cs = customer specs · cu = customer unit

Subject to alterations

### 3.3 Technical description

<b>Mass</b>	4.35 kg
<b>Size</b>	170 mm
<b>Surface of rotor</b>	Coated in black
<b>Material of protective cover</b>	Polyflam RPP 374-ND CS1 (UL 97-V0)
<b>Material of impeller</b>	Aluminium sheet
<b>Housing material</b>	Die-cast aluminium
<b>Direction of rotation</b>	Clockwise, seen on rotor
<b>Type of protection</b>	IP 20
<b>Insulation class</b>	"B"
<b>Mounting position</b>	Any
<b>Cooling bore / aperture</b>	Rotor-side
<b>Premix</b>	If gas is premixed in the blower, a special blower must be used.
<b>Motor bearing</b>	Ball bearing
<b>Technical features</b>	- Control input PWM - Motor current limit - Tach output - Overtemperature-protected motor
<b>Leakage current</b>	≤ 3.5 mA
<b>Electrical leads</b>	With plug
<b>Motor protection</b>	Thermal overload protector (TOP) wired internally
<b>Approval</b>	UL 507; CSA C22.2 Nr.113



For cyclic speed loads, note that the rotating parts of the device are designed for maximum one million load cycles. If you have specific questions, contact ebm-papst for support.

### 3.4 Mounting data

For depth of screw, see chapter 3.1 Graphic rendition of products

- Secure the mounting screws against accidentally coming loose (e.g. by using self-locking screws).

<b>Strength class for mounting screws</b>	8.8
---	-----

You can obtain additional mounting data from the product drawing if necessary.

### 3.5 Transport and storage conditions

- Use the device in accordance with its protection type.

<b>Max. permissible ambient motor temp. (transp./ storage)</b>	+80 °C
<b>Min. permissible ambient motor temp. (transp./storage)</b>	-40 °C

### 3.6 Electromagnetic compatibility

<b>EMC interference immunity</b>	Acc. to EN 61000-6-2
<b>EMC interference emission</b>	Acc. to EN 61000-6-3 (household environment)



## 4. CONNECTION AND START-UP

### 4.1 Connecting the mechanical system



#### DANGER

##### Gas leaking from improperly sealed housing

Risk of fatal injury

- Prior to commissioning, check that the housing of the gas blower is pressure-tight. When doing so, close the intake and exhaust opening and the shaft opening.
- In addition, check that rotating parts do not scrape against stationary parts.



#### DANGER

##### Leaks may occur.

As a result of design necessities, the gas blower is not tightly sealed, e.g. at the shaft opening. This may cause leaks during operation. Deflagrations may also cause long-term damage or deformation of the housing, which can result in leaks. An air/gas mixture may accumulate outside of the gas blower. The blower may explode. You could be severely injured.

- Check which hazards arise from installing, operating, servicing or disposing of the gas blower in conjunction with your device. Prevent these hazards. Carry out all appropriate measures to this purpose.



#### CAUTION

##### Cutting and crushing hazard when removing the blower from the packaging



- Carefully remove the blower from its packaging, only touching the housing. Make sure to avoid any shock.
- Wear safety shoes and cut-resistant safety gloves.

- ; Check the device for transport damage. Damaged devices must no longer be installed.
- ; Install the undamaged device according to your application.

### 4.2 Connecting the electrical system



#### DANGER

##### Electric voltage on the device

Electric shock

- Always install a protective earth.
- Check the protective earth.



#### DANGER

##### Incorrect insulation

Risk of fatal injury from electric shock

- Use only cables that meet the specified installation requirements for voltage, current, insulation material, load etc.
- Route cables such that they cannot be touched by any rotating parts.



#### DANGER

##### Electrical load (>50 µC) between mains wire and protective earth connection after switching of the supply when switching multiple devices in parallel.

Electric shock, risk of injury

- Make sure that sufficient protection against accidental contact is provided. Before working on the electrical connection, the connections to the mains supply and PE must be shorted.

#### CAUTION

##### Electrical voltage

The device is a built-in component and features no electrically isolating switch.

- Connect the device only to circuits that can be switched off using an all-pole disconnecting switch.
- When working on the device, you must switch off the system/machine in which the device is installed and secure it from being switched on again.

#### NOTE

##### Water penetration into leads or wires

Water enters at the cable end on the customers side and can damage the device.

- Make sure that the cable end is connected in a dry environment.



The control voltage circuit is not electrically isolated. Connect the device only to circuits that can be switched off using an all-pole disconnecting switch.

#### 4.2.1 Prerequisites

- ; Check whether the data on the type plate agree with the connection data.
- ; Before connecting the device, ensure that the supply voltage matches the operating voltage of the device.
- ; Only use cables designed for current according to the type plate. For determining the cross-section, follow the basic principles in accordance with EN 61800-5-1. The protective earth must have a cross-section equal to or greater than the outer conductor cross-section. We recommend the use of 105°C cables. Ensure that the minimum cable cross-section is at least AWG26/0.13 mmL.

#### 4.2.2 Idle current



Because of the EMC filter integrated for compliance with EMC limits (interference emission and interference immunity), idle currents in the mains cable can be measured even when the motor is at a standstill and the mains voltage is switched on.

- The values lie in a range of typical < 250 mA.
- The effective power in this operating state (readiness for operation) is simultaneously at typical < 4 W.

#### 4.2.3 Locked-rotor protection



Due to the locked-rotor protection, the start-up current (LRA) is equal to or less than the nominal current (FLA).

### 4.3 Connection via plug

#### 4.3.1 Preparing connection lines for the connection



The lines, including customer-side interface, fall within the standard of the internal connection.

Observe product conformity to standards and the type of protection in your end device after you have installed the ebmpapst device.

- ; Connect the connection lines to the mating connectors.

### 4.3.2 Establish supply connections

**CAUTION****Electrical voltage**

The device is a built-in component and features no electrically isolating switch.

- Connect the device to a suitable trigger device. Connect the device only to circuits that can be switched off using an all-pole disconnecting switch.
- When working on the device, you must switch off the system/machine in which the device is installed and secure it from being switched on again.

- ; Check the PIN assignment of your connector.
- ; Connect the panel connector and mating connector.
- ; Ensure that the connector is locked in correctly.





## 4.4 Connection diagram

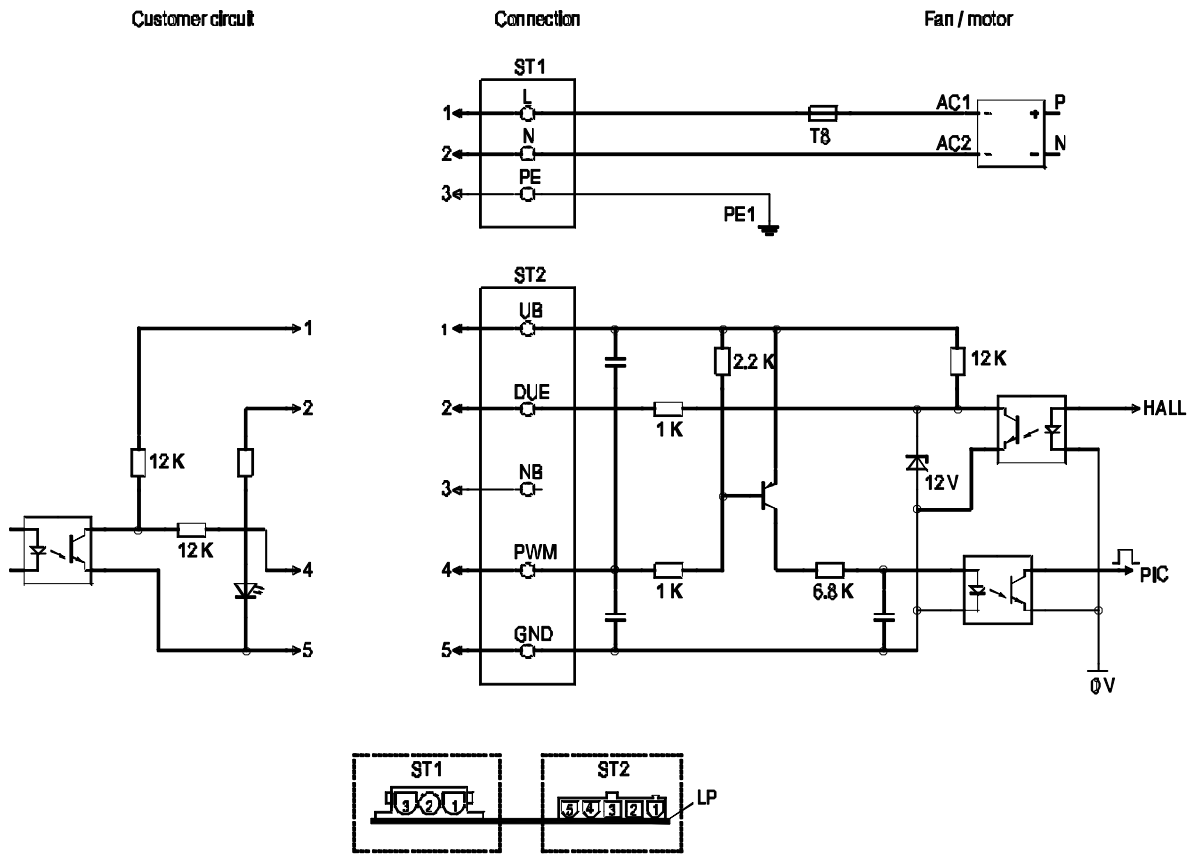

No.	Pin	Signal	Function / assignment
ST1	1, 2, 3	L, N, PE	Power supply 115 VAC, 50-60 Hz, neutral conductor, protective earth
ST2	1	UB	External voltage 24-45 VDC
ST2	2	DUE	Speed monitoring output connection, monitoring circuit output, 3 pulses per revolution, current source 1 mA
ST2	3	N.C.	Not assigned
ST2	4	PWM	PWM - 2-6 kHz control input, PWM on n = 100%, PWM low n = 0%
ST2	5	GND	GND - Connection for control interface

#### 4.5 Checking the connections

- ; Make sure that the power is off (all phases).
- ; Secure it from being switched on again.
- ; Check that the mating connector is correctly locked into the panel connector.
- ; Check that the mating connector is correctly crimped to the connection line.

#### 4.6 Switch on device



##### WARNING

##### Hot motor housing

Fire hazard

→ Ensure that no combustible or flammable materials are located close to the blower.

- ; Inspect the device for visible external damage and the proper function of the protective features before switching it on.
- ; Check the air flow paths of the fan for foreign objects and remove any that are found.
- ; Apply 0 VDC to the 0-10 V control input (if you are using the control input)
- ; Apply 0 % PWM to the PWM control input (if you are using the PWM control input)
- ; Apply the nominal voltage to the voltage supply.
- ; Start the device by changing the input signal.

#### 4.7 Switching off the device

Switching off the device during operation:

- ; Switch on the device via the control input.
- ; Do not switch the motor (e.g. in cyclic operation) on and off via power supply.

Switching off the device for maintenance work:

- ; Switch on the device via the control input.
- ; Do not switch the motor (e.g. in cyclic operation) on and off via power supply.
- ; Disconnect the device from the supply voltage.
- ; When disconnecting, be sure to disconnect the earth wire connection last.

#### 5. INTEGRATED PROTECTIVE FUNCTIONS

The integrated protective functions cause the motor to switch off automatically in case of faults described in the table.

Malfunctions	Description / Function of safety feature
Rotor position detection error	An automatic restart occurs.
Locked rotor	; After the blockage is removed, the motor restarts automatically.

## 6. MAINTENANCE, MALFUNCTIONS, POSSIBLE

### CAUSES AND REMEDIES

Do not perform any repairs on your device. Return the device to ebmpapst for repair or replacement.

**WARNING**

**Terminals and connections have voltage even with a unit that is shut off**

Electric shock

→ Wait five minutes after disconnecting the voltage at all poles before opening the device.

**CAUTION**

**If the control signal of a blower that is connected to the power system is removed, the motor can restart automatically.**

Danger of injury

→ When working on the blower, switch off the mains supply voltage and secure it from being switched on again.

→ Wait until the device stops.

**CAUTION**

**Electrical load after device is switched off**

Electric shock in case of contact

→ Wait for five minutes after disconnecting the voltage at all poles before touching the unit.

**CAUTION**

**If control voltage is applied or a speed setpoint is stored, the motor automatically restarts, e.g. after a power failure.**

Danger of injury

→ Keep out of the danger zone of the device.

→ When working on the device, switch off the mains supply voltage and secure the latter from being switched on again.

→ Wait until the device stops.

→ After working on the device, remove any used tools or other objects from the device.



If the blower remains out of use for some time, e.g. when in storage, we recommend switching the blower on for at least 2 hours to allow any condensate to evaporate and to move the bearings.

Malfuction/error	Possible cause	Possible remedy
<b>Impeller running roughly</b>	Imbalance in rotating parts	Clean the device; if imbalance is still evident after cleaning, replace the device. If you have attached any weight clips during cleaning, make sure to remove them afterwards.
<b>Motor does not turn</b>	Mechanical blockage	Switch off, de-energise, and remove mechanical blockage.

	Mains supply voltage faulty	Check mains supply voltage, restore power supply, apply control signal.
	Faulty connection	De-energise, correct connection, see connection diagram.
	Thermal overload protector responded	Allow motor to cool off, locate and rectify cause of error, if necessary cancel restart lock-out
<b>Overtemperature of electronics/motor</b>	Insufficient cooling	Improve cooling. Let the device cool down. To reset the error message, switch off the mains supply voltage for a min. of 25 s and switch it on again.
	Ambient temperature too high	Reduce the ambient temperature. Reset by reducing control input to 0.
	Unacceptable operating point	Correct the operating point. Let the device cool down.
<b>Deflagration</b>	Leakage of the handled air/gas mixture	Check for leaks; replace blower if not properly sealed



If you have any other problems, contact ebm-papst.

### 6.1 Cleaning

**NOTE**

The device does not need to be cleaned.

### 6.2 Safety test

**NOTE**

**High-voltage test**

The integrated EMC filter contains Y capacitors. Therefore, the trigger current is exceeded when AC testing voltage is applied.

→ Test the device with DC voltage when you carry out the high-voltage test required by law. The voltage to be used corresponds to the peak value of the AC voltage required by the standard.

What has to be tested?	How to test?	Frequency	Which measure?



Check the protective casing against accidental contact for damage and to ensure that it is intact	Visual inspection	At least every 6 months	Repair or replacement of the device
Check the device for damage to blades and housing	Visual inspection	At least every 6 months	Replacement of the device
Mounting the connection lines	Visual inspection	At least every 6 months	Fasten
Mounting of protective earth connection	Visual inspection	At least every 6 months	Fasten
Check the insulation of the wires for damage	Visual inspection	At least every 6 months	Replace wires
Condensate discharge holes for clogging, as necessary	Visual inspection	At least every 6 months	Open bore holes
Check the ball bearings to ensure they are quiet, can move easily and are free of play	Manual check by turning the rotor in shut-off state	At least every 6 months	Replace device in case of noise, difficulty of movement or clearance of the bearings



